

V. F. Bukharov, V. A. Vasyukov, V. E. Gurin,  
D. I. Zenkov, A. S. Kravchenko, R. Z. Lyudaev,  
A. I. Pavlovskii, Yu. I. Plyushchev,  
L. N. Plyashkevich, and A. M. Shuvalov

UDC 538.4:621.365.21

Magnetic cumulation generators are promising as high-power pulsed energy sources [1-3]. When the load is connected directly in the circuit of the magnetic cumulation generator (MCG), efficient operation is possible only if constraints are imposed on the load parameters. In many applications, the inductance and resistance of the load substantially exceed those of the MCG, while the load parameters vary when the generator is working, and the time required to input the energy to the load differs from the generator working time.

One way of matching MCG parameters to a load is to use a step-up transformer, with the load connected to the secondary winding and the MCG to the primary one. Transformer energy output from an MCG was reported in 1965 [2]. Subsequent publications [4-6] describes a series of designs of MCG with transformers, which are considered within the framework of the electrotechnical model as regards matching to resistive and inductive loads, and also parameter optimization. The connection of capacitative components in the load circuit is of interest for some physics research [7]. A transformer can be used with various switching components to regulate the energy input time to the load within certain limits. Transformer connection can also be used in cascade MCG systems with large energy-amplification factors. Here we describe a series of MCGs with transformer units together with experimental results on these, and also on cascade systems built from these generators.

The complicated geometry of the transformer hinders calculation of a transformer MCG, and good results in engineering calculations are provided by the electrotechnical model for an MCG. Numerical solution of the electrotechnical equations provides the optimal values of inductance and resistance in the load. If the load deviates from optimal, the output energy is reduced, and the acceptable limits to this reduction define the region of load matching to the MCG. The width of the matching region is particularly important if one uses a load with variable parameters, and it increases with the transformation coefficient. It has also been suggested [7] that an MCG should be used as a charging device for a fast capacitor store. The operation of an MCG into a capacitance involves the possibility of current oscillations. When a capacitor is fed from an MCG via a transformer, no current oscillations arise within the MCG even if high-frequency oscillations occur in the secondary circuit.

Various forms of energy-supply circuits based on transformers with MCG with switching facilities have been used to adjust the shape of the current pulse in the load. The current in the secondary circuit is less than that in the MCG, which facilitates use of a circuit in which the current is interrupted by an explosion or with an exploding wire [1]. The leading edge of the current in the load can also be shortened within certain limits by using the transformer on open circuit in the initial stages of the MCG operation [8]. If the transformer continues to function up to the end of MCG operation, one can use an additional part of the energy remaining in the MCG circuit, which is lost if the transformer is destroyed.

If the required transformer operating time is of the same order as the MCG operating time, the transformer can be located directly in the MCG, which enables one to increase the coupling coefficient  $k$  and reduces the specifications for the line transmitting the energy to the load. In that case the transformer is destroyed, and therefore the decisive features are simplicity and cheapness in the design, while the mechanical strength can be reduced.

As the magnetic fields are high, only air-cored designs are used, which provide maximum coupling. The dimensions of the transformer are determined in the main by the required inductance  $L_{1t}$  of the primary windings together with the necessary quality factor for the windings. Single-turn primary windings are frequently used. It is also possible to use a primary

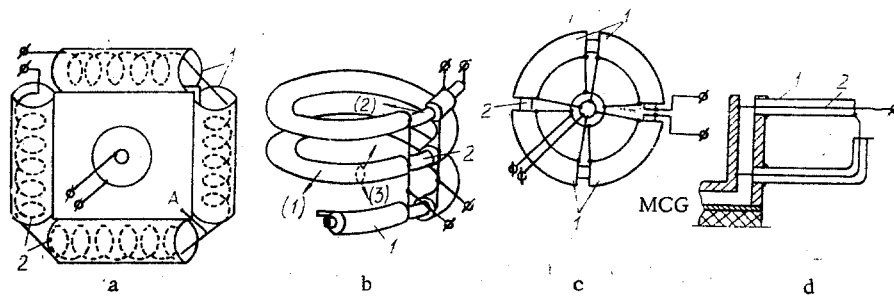

Fig. 1

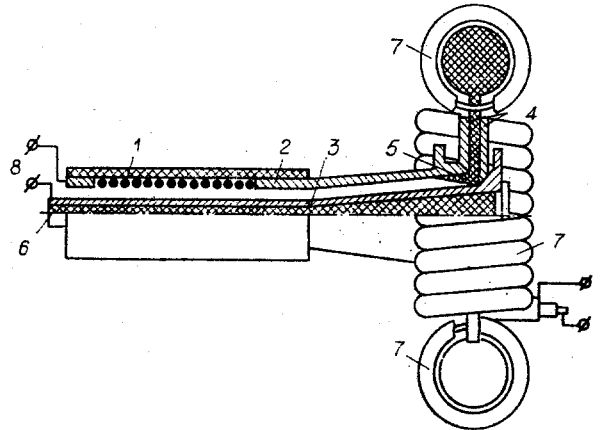

Fig. 2

winding in the form of several circuits which do not interact inductively and which work into a common secondary turn.

Figure 1 shows some design schemes for the transformers. A cylindrical transformer is convenient for connection to transmission-line MCG [1] and its parameters are determined from the known relationships for solenoids. When the MCG operates, the winding resistance will vary on account of diffusion of the magnetic field into the transformer conductors. The secondary circuit is made of multistart type in order to reduce the resistance. The displacement of the conductors when the MCG operates amounts to radial expansion of the primary winding together with compression of the secondary one and axial displacement of the ends. The upper boundary of these displacements is proportional to  $\int (H^2 dt) dt$ , where H is the strength of the magnetic field at the surface of the conductor and is inversely proportional to the mass of the conductor per unit surface area.

The configuration of Fig. 1a is convenient for connecting such a transformer to a coaxial or spiral MCG, where the primary windings 1 of the transformers are connected at the perimeter to the two current-conducting plates. The secondary windings 2 of the transformers may be taken to the load from each transformer independently or as in Fig. 1a, where the secondary winding is common. It is desirable in that case to have a common point on the windings A, which reduces to about half the specifications for the working voltage on the insulation between the windings, but then if the load is grounded there will be a voltage between the body of the MCG and ground approximately equal to half the output voltage. The primary winding of the transformer may be made as a toroid mounted on the MCG of rectangular or circular cross sections, with a secondary winding as a toroidal solenoid placed within the primary one.

Figure 1b shows the circuit for a cable transformer [9] as applied to an MCG. The load can also be connected to the two ends of the cable, which reduces the requirements for cable insulation. The leakage inductance of the secondary winding is determined by the cable inductance and can be reduced by using parallel cables, which reduces the resistance and also the current per cable. The displacement (1) is due to radial expansion of the turns, while the displacement (2) of parts of the wire in the cable not having a sheath is determined by the difference between the fields in the current lead and within the transformer, and the displacement (3) of the cable sheath is determined by the current flowing in it. In the case of

TABLE 1

Type of MCG	K-80	K-160	K-320	Type of MCG	K-80	K-160	K-320
$L_0, \mu\text{H}$	20	1,4	1,2	$U, \text{kV}$	75	110	100
$N$	32	16	8	$P, \text{TW}$	0,02	0,12	0,5
$L_{3T}, \text{nH}$	14	25	50	$W_0, \text{kJ}$	2,5	200	1800
$L_{2T}, \mu\text{H}$	14,5	6,8	3	$W_f, \text{MJ}$	0,5	5,1	31
$L_L, \mu\text{H}$	6,5	3	1,5	$W_{mf}, \text{MI}$	0,25	3	20
$L_{ef}, \text{nH}$	5	10	16	$k$	0,95	0,96	0,97
$T, \mu\text{sec}$	100	200	250	$\Phi_{ef}$	0,22	0,5	0,55
$I_{10}, \text{kA}$	16	500	1700	$\Psi_f$	0,5	0,58	0,65
$I_{1f}, \text{MA}$	14	32	64	$w_{mf}$	100	20	11
$I_{2f}, \text{MA}$	0,26	1,4	5,5				



Fig. 3

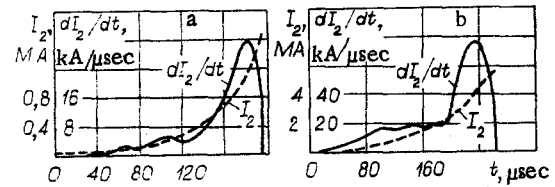

Fig. 4

cable transformer in the form of a cylindrical solenoid, one also has to consider the end displacements. One can also construct a toroidal cable solenoid of the form shown in Fig. 1c. Here the primary winding 1 is several sectors of a turn of cable sheath connected to the current flanges of the MCG and encompassed by the common turn of cable inner. The transformation coefficient is then approximately equal to the number of sectors. The secondary winding 2 in such a transformer may consist of several turns of parallel cables. An advantage of this transformer is the lower consumption of cable.

In the two-turn cable transformer of Fig. 1d, one can use the possibility of connecting the load to a break in the sheath at any point on the cable. Therefore, the transformer can be given an elongated form, which increases  $L_{1T}$ , the dimensions of the transformer, and enables one to use it as a transmission line to the load.

A set of MCG designs has been devised in which each consists of a spiral generator in combination with a coaxial cone MCG [3], this being fitted with transformer units. Figure 2 shows the design scheme for such a generator. The generator is built as two separate units (the MCG unit and the transformer unit), which are joined together reliably. The multistart spiral 1 is wound with insulated copper wire, and it is reinforced on the outside by a concrete shell. The coaxial part 2 has a conical expansion whose angle is close to the angle of divergence of the walls of the copper central tube 3 produced by explosion of the charge 6. The MCG is connected to the transformer unit via two square plates 4 separated by the insulator 5, to each side of which is connected the transformer 7 wound with cable. The initial energy is supplied to input 8 of the generator, while the load is connected to output 9. The generator is mounted on a metallic support. The overall efficiency of such a generator is about 8%.

Figure 3 shows a general view of a K-80 generator. Spiral characteristics: multistart, internal diameter 80 mm, six sections of length 80 mm each, pitches of sections 5, 10, 20, 40, 80, and 200 mm, wound with wire of diameter 2.5 mm. The coaxial part is of length 260 mm, while the copper central tube has an outside diameter of 23 mm and a wall thickness of 2 mm and has a conical expansion with an angle of  $4^\circ$ , while the explosive charge is 0.8 kg. The transformer unit consists of four cylindrical transformers with a 32-turn secondary winding placed within the primary turn. Table 1 gives the characteristics of this generator, where  $L_0$  is the initial inductance of the MCG,  $N$  is the number of turns on the secondary winding,  $L_{2T}$  is the inductance of the secondary winding,  $L_L$  is the load inductance,  $L_{ef}$  is the final value of the MCG inductance (the subscript e indicates the effective value, while f indicates the final value),  $T$  is the MCG working time,  $I_{10}$  is the initial current in the MCG,  $I_{1f}$  and  $I_{2f}$  are the final currents in the primary and secondary windings,  $U$  is the output voltage,  $P$

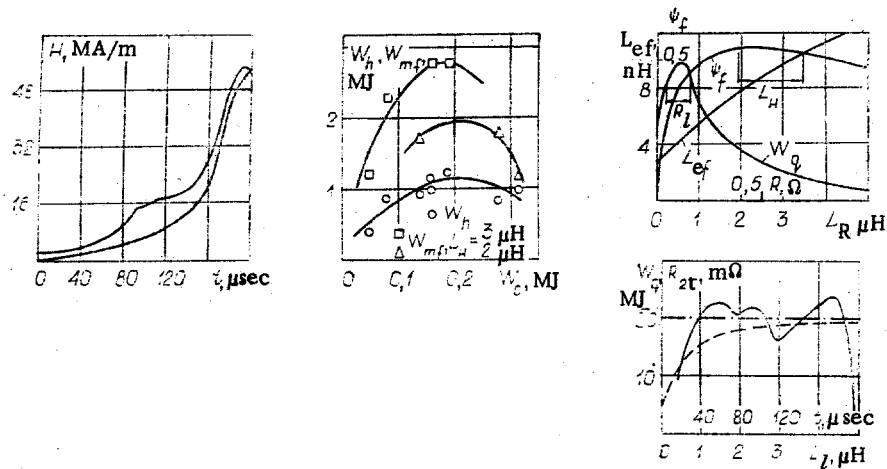

Fig. 5

is the peak power,  $W_0$  is the initial energy in the MCG,  $W_f$  is the final value of the magnetic energy in the circuits,  $W_{mf}$  is the energy in the inductive load,  $\varphi_{ef}$  is the final value for the magnetic-flux conservation coefficient, and  $\psi_f = W_{mf}/W_f$ ,  $w_{mf} = W_{mf}/W_0$ . The K-80 generator is fed from capacitors. There is also a form of this generator with a cable transformer having analogous characteristics.

The K-160 generators has a spiral with an internal diameter of 160 mm wound with insulated copper wire of diameter 4 mm, which consists of two sections of length 320 mm each with two turns each, while the coaxial part of length 640 mm has a conical expansion with an angle of  $7^\circ$ . The central tube with an outside diameter for the cylindrical part of 80 mm and a wall thickness of 4 mm contains 10 kg of explosive. The overall weight of the generator with support is 450 kg.

Table 1 gives the parameters of the generator together with experimental results.

Figure 4a shows the observed curves for  $I_2$  and  $dI_2/dt$  for a K-160. Figure 5a shows the change in magnetic field in the cavity of the coaxial at various radii, which does not exceed 60 MA/m in all generators. Figure 5b shows the dependence of the observed value of  $W_h$  (the value of  $W$  at the end of operation of the spiral) and of  $W_{mf}$  on  $W_0$ . Figure 5c shows the theoretical dependence of  $L_{ef}$  and  $\psi_f$  for  $R_L = 0$  ( $R_L$  is the load resistance) on  $L_L$ , and also the dependence of  $W_{qf}$  on  $R_L$  ( $L_L = 0$ ,  $I_{20} = 0$ ). The matching range in  $L_L$  is determined for this generator by the values of  $L_{ef}$  and  $\psi_f$  and is 2-3.5  $\mu\text{H}$ , while the width of the matching range in  $R_L$  is from 0.04 to 0.1  $\Omega$ . Figure 5d shows the change in internal resistance of the secondary winding  $R_{2t}$  due to the change in the equivalent frequency during the operation of the MCG, which fluctuates at the level of 5-10 kHz. This also shows the variation in  $R_{2t}$  as a function of the change  $\alpha = L_L/L_{2t}$  measured before the experiment at 10 kHz. The broken line shows the value taken as constant in the calculations.

Transformer units with 4- and 8-turn secondary windings (with correspondingly larger numbers of parallel cables) were developed for this generator, and also 32- and 64-turn ones obtained by series connection of 16-turn transformers. When the number of turns is doubled,  $I_{2f}$  is approximately halved, while  $U$  is doubled and the matched values of  $L_L$  and  $R_L$  are increased by factors of four. For  $N = 64$ ,  $U \sim 400$  kV,  $L_L$  is up to 100  $\mu\text{H}$ , and  $R_L$  is in the order of several ohms.

The generator can use the initial energy of a capacitor bank or another MCG. An MCG unit was developed having an elevated amplification coefficient with supply from capacitors. The spiral has six sections each 160 mm long (16, 8, 4, 2, 1, and 0.5 turns) with  $L_0 = 35$   $\mu\text{H}$ . With  $W_0 = 20$  kJ, the generator had the same final parameters, and  $w_{mf} = 150$ . The transformer units and MCG units in all forms are interchangeable.

Figure 6 gives a general view of the K-320 generator. The spiral in this generator was wound with insulated wire having copper of diameter 9 mm. The first section of length 640 mm had two turns, while the second of length 320 mm had 0.5 turn. The length of the coaxial part was 960 mm. The outside diameter of the copper central tube was 160 mm, the wall thickness 8 mm, and the cone angle was  $7^\circ$ . The transformer with  $N = 8$  was wound with the cable used in the K-160 on a framework of diameter 440 mm and length 750 mm. The generator was fed

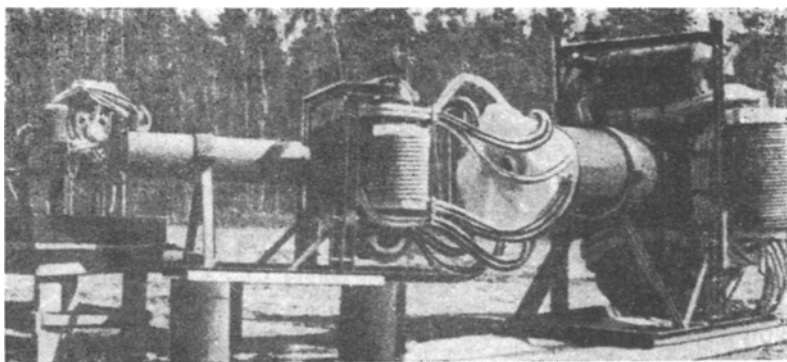

Fig. 6

from another MCG. The mass of the generator with support was 2200 kg, and the explosive charge was 59 kg. Figure 4b shows the observed  $I_2$  and  $dI_2/dt$  curves for this generator.

An advantage of a transformer generator is the wider range of parameters for the possible loads, which improves the universality of MCG. This also facilitates operation of an MCG into a load with variable parameters, e.g., in plasma research [10].

These generators can also be used in other traditional areas of MCG application, e.g., to supply the initial-field solenoid in an MK-1 generator, etc. The K-160 generator connected in a circuit using open-circuit conditions has been used to supply an air-cored betatron [11], supplying an energy of about 1 MJ in an unstressed state with  $\tau = 100 \mu\text{sec}$ .

Transformer coupling can also be used in cascade MCG systems, in which each previous generator is the source of the initial energy for the next. The MCG circuit can be considered basically as an inductive load, and the parameters of the transformer in the previous generator can be chosen appropriately. The transformer can work on open-circuit conditions or even with magnetic-flux trapping, since shortening of the leading edge of the current improves the operation of a spiral generator.

If one connects a cascade of  $n$  generators with identical  $w_{mf}$ , then the energy amplification coefficient for the entire cascade will be  $w_{mf}^n$ . A transformer allows one to obtain a magnetic flux in the load exceeding the initial one, and this enables one to connect a cascade of generators with increasing initial inductances and increasing size. The output energy naturally increases with the size of the MCG. Also, the overall efficiency of the system is determined in the main by the generator in the last stage, so that preceding generators can be designed for lower efficiency but higher  $w_{mf}$ . Figure 6 shows a cascade system built of K-80, K-160, and K-320 generators. The system consumes  $W_0 = 2 \text{ kJ}$  and has  $w_{mf} = 10^4$ . The system employs a K-160 generator with an 8-turn transformer unit with a 6-section spiral in which the first section is absent,  $L_0 = 6.5 \mu\text{H}$ .

When a cascade system is continued towards the low-energy side, it becomes undesirable from a certain point to reduce the size of the MCG any further, since spiral generators in the unloaded state have higher  $w_{mf}$ . An example is provided by the cascade scheme of [12], which is composed of six identical generators with a spiral diameter of 30 mm linked by toroidal cable transformers, and which provide a load energy of about 1.5 kJ on using 0.2 J of energy from permanent magnets. This cascade (Fig. 6) is fed from this system, and the overall energy gain of the entire device is about  $10^8$ . In turn, the K-320 can serve as a source of initial energy for an MCG of even higher energy. At present, transformer connection causes no difficulty in linking generators ranging from the minimum to the maximum possible for MCG to give a single cascade system. Clearly, the minimum level in the cascade system is determined by the competitiveness of an MCG with other generators at low energies.

Therefore, these generators can be used independently and in cascade systems. This set of MCG also allows the output parameters to be matched to the load requirements and provides for pulse shaping, which substantially expands the use of MCG.

#### LITERATURE CITED

1. H. Knoepfel, Pulsed High Magnetic Fields, American Elsevier, New York (1970).
2. V. E. Gurin, R. Z. Lyudayev, et al., "MC-2 transformer system," in: Megagauss Magnetic Field Generation by Explosives and Related Experiments, EUR 2750e, Euratom, Brussels (1966).

3. J. W. Shearer et al., "Explosive-driven magnetic field compression generators," J. Appl. Phys., **39**, 2102 (1968).
4. E. I. Bichenkov, "Explosive generators," Dokl. Akad. Nauk SSSR, **174**, No. 1 (1967).
5. D. B. Cummings, "Cascading explosive generators with autotransformer coupling," J. Appl. Phys., **40**, No. 10 (1969).
6. L. S. Gerasimov, "Matching an explosive magnetic generator to an inductive load," Zh. Tekh. Fiz., **44**, No. 9 (1974); "Matching an explosive magnetic generator to a resistive load with a transformer," Zh. Prikl. Mat. Tekh. Fiz., No. 4 (1978).
7. A. I. Pavlovskii and V. S. Bosamykin, "Iron-free linear induction accelerators," At. Energ., **37**, No. 3 (1974).
8. A. I. Pavlovskii, R. Z. Lyudaev, et al., "An explosive magnetic generator," Byull. OIPOTZ, No. 11 (1970).
9. V. B. Gaaze and G. A. Shneerson, "A high-voltage cable transformer for the production of heavy current pulses," Prib. Tekh. Eksp., No. 6 (1965).
10. A. E. Voitenko, E. P. Matochkin, and B. A. Yablochnikov, "Use of an explosive magnetic generator to supply a gas discharge," Prib. Tekh. Eksp., No. 3 (1973).
11. A. I. Pavlovskii, et al., "A pulsed iron-free betatron supplied from a magnetic cumulation generator," At. Energ., **41**, No. 2 (1976).
12. A. I. Pavlovskii, et al., "Transformer energy output magnetic cumulation generators," in: Megagauss Physics and Technology, Plenum Press, New York (1980).

CURRENT AND ELECTRIC-FIELD PRODUCTION NEAR A NONCONDUCTING  
ROTATING SPHERE IN A HOMOGENEOUS PLASMA IN A STRONG MAGNETIC FIELD

V. G. Pivovarov

UDC 533:538 + 550:38

Central problems in magnetosphere physics include the motion of the plasma near the rotating earth and the currents and electromagnetic fields generated by this rotation. We consider the following model problem in order to obtain a conception of the structure of the current system and the motion of the plasma. An insulating sphere of radius  $r_0$  is surrounded by a homogeneous incompressible conducting liquid and rotates with an angular velocity  $\omega$ . At the center of the sphere there is a magnetic dipole, whose moment coincides in direction with the axis of rotation. The plasma density  $\rho$ , conductivity  $\sigma$ , and viscosity  $\mu$  are independent of the coordinates.

We assume that all the perturbations associated with the rotation decay away from the surface of the sphere. The attachment condition is obeyed at the surface of the sphere itself, while the normal component of the current becomes zero.

The behavior of the plasma is described by the equations of magnetohydrodynamics [1]

$$\begin{aligned} \rho(\mathbf{u}\nabla)\mathbf{u} + \nabla(p + H^2/8\pi) &= (\mathbf{H}\nabla)\mathbf{H}/4\pi + \mu\Delta\mathbf{u}, \\ \operatorname{div}\mathbf{u} &= 0, \operatorname{div}\mathbf{H} = 0, \operatorname{rot}[\mathbf{u}\mathbf{H}] + \nu_m\Delta\mathbf{u} = 0, \end{aligned} \quad (1)$$

where  $\mathbf{u}$  and  $\mathbf{H}$  are the speed of the plasma and the magnetic field,  $p$  is the plasma pressure, and  $\nu_m$  is the magnetic viscosity, which is related to the conductivity  $\sigma$  by

$$\nu_m = c^2/4\pi\sigma.$$

The magnetic field within the sphere satisfies the equations

$$\operatorname{rot}\mathbf{H}^{in} = 0, \operatorname{div}\mathbf{H}^{in} = 0.$$

If the total magnetic field  $\mathbf{H}$  is represented as  $\mathbf{H}^{in} = \mathbf{H}_D + \mathbf{h}$ , where  $\mathbf{H}_D$  is the dipole magnetic field and  $\mathbf{h}$  is the perturbation field, then we introduce the scalar potential  $\Phi$  for the magnetic field  $\mathbf{h}$  by  $\mathbf{h} = \nabla\Phi$ , which gives

$$\Delta\Phi = 0. \quad (2)$$

The magnetic field does not change on passing through the surface of the sphere, so  $\Phi$  should satisfy the following at the boundary:

---

Krasnoyarsk. Translated from Zhurnal Prikladnoi Mekhaniki i Tekhnicheskoi Fiziki, No. 1, pp. 10-15, January-February, 1982. Original article submitted November 5, 1980.